



MG127 BLE Transceiver

Application Note

Revision History:

Rev. No.	History	Issue Date	Remark
0.1	Initial issue	April 29, 2016	Preliminary
0.2	Update ch10 about PCB	July 11, 2016	Preliminary
0.3	Update MISO description	Jan 19, 2017	Preliminary
1.0	Add receive characteristic	Jan 31, 2018	Release
1.1	Update receive characteristic	April 2, 2018	Release
1.2	Update reflow profile	May 24, 2018	Release
1.3	Add carrier output	July 25, 2018	Release

Important Notice:

MACROGIGA reserves the right to make changes to its products or to discontinue any integrated circuit product or service without notice. MACROGIGA integrated circuit products are not designed, intended, authorized, or warranted to be suitable for use in life-support applications, devices or systems or other critical applications. Use in such applications is done at the sole discretion of the customer. MACROGIGA will not warrant the use of its devices in such applications.



目录

1. 概述.....	3
2. MG127 管脚描述.....	3
3. 数据和控制接口.....	4
4. 寄存器信息.....	5
5. 应用电路原理图.....	6
6. 电气特性.....	7
7. 功耗指标.....	7
8. MG127 封装.....	8
9. Reflow Profile.....	9
10. PCB 布线注意事项.....	10
11. 载波输出.....	11
12. FAQ.....	11



1. 概述

MG127 是低功耗、低成本的 BLE 收发器，内部集成了发射机、接收机、GFSK 调制解调器和 BLE 基带处理。MG127 采用 DFN3x3 封装，只需搭配低成本 MCU 和少数外围被动器件，即可实现 BLE 遥控、蓝牙电子秤等应用。

- 电源电压 1.9~3.6，可以采用一个纽扣电池（3.0v）供电
- 3uA 待机电流
- 20mA@0dBm 持续发射
- 18mA 持续接收
- DFN3x3 封装，外围 BOM 很少
- 只需低成本 MCU 配合

2. MG127 管脚描述

MG127 采用 DFN10 封装，芯片大小为 3mm x 3mm。

Pin No.	Symbol	I/O	Function Description
1	SCK	DI	SPI Clock
2	DVDD	Power	Digital VDD 1.2v Output
3	MOSI	DI/DO	SPI Slave Data Input/Output
4	XTALO	AO	Crystal Pin
5	XTALI	AI	Crystal Pin
6	ANT	RF	Antenna interface
7	VBAT	Power	Power Supply
8	IRQ	DO	Interrupt pin
9	CT	DI	Test use
10	CSN	DI	SPI Chip Select
11*	GND	Ground	Power ground, back panel

Table2.1 Pin Description



3. 数据和控制接口

MG127 通过 3 线 SPI 接口和 IRQ 信号与 MCU 进行通信，接口包括以下信号：

- IRQ (this signal is active low and is controlled by maskable interrupt sources)
- CSN (SPI signal)
- SCK (SPI signal)
- MOSI (SPI signal)

其中 MOSI 信号用于输入和输出。MCU 可以用 3 个 GPIO 模拟 SPI，我们提供 3 线 SPI 的参考 C 源码。

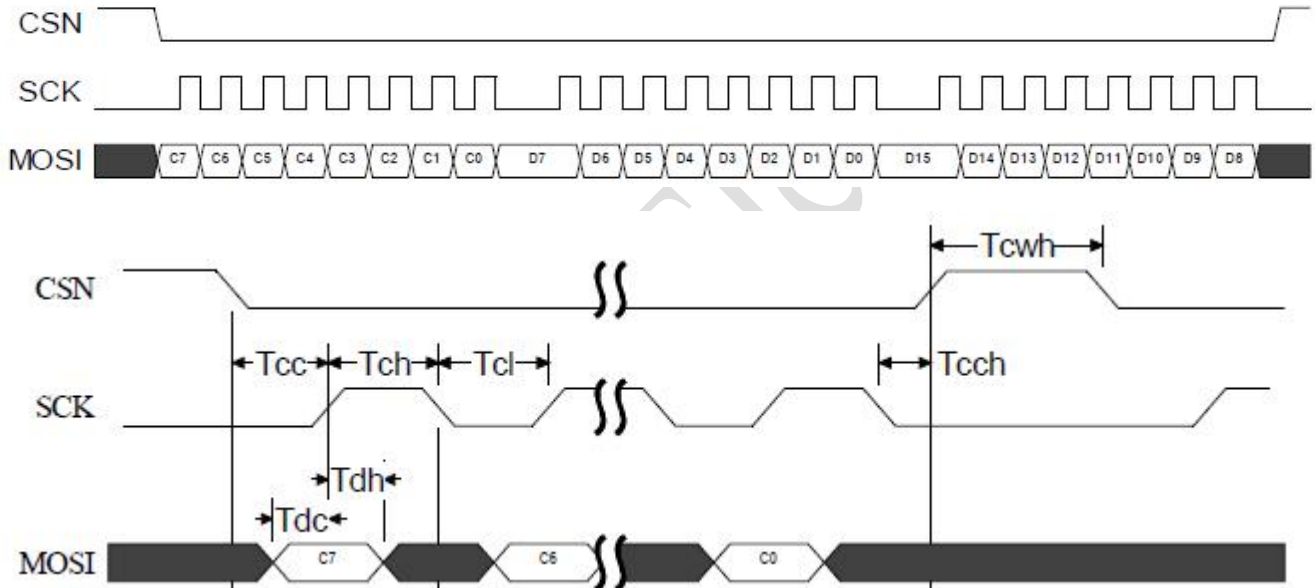

Figure3.1 SPI timing diagram

Symbol	Parameters	Min.	Max	Unit
Tcc	CSN to SCK setup	2	-	ns
Tch	SCK high time	40	-	ns
Tcl	SCK low time	40	-	ns
Tcwh	CSN inactive time	50	-	ns
Tcch	SCK to CSN hold	2	-	ns
Tdc	Data to SCK setup	2	-	ns



Tdh	SCK to Data hold	2	-	ns
-----	------------------	---	---	----

4. 寄存器信息

可以通过 SPI 访问这些寄存器。

Address (Hex)	Mnemonic	Bit	Reset Value	Description
01	CH_NO			BLE channel
		7:6	0	reserved
		5:0	0	BLE advertise channel number(37,38,39)
02	MODE_TYPE			ADV/Data Tx/Rx mode
		7:4	0	reserved
		3	1	Adv event
		2	0	Tx enable
		1:0	00	01 - Rx enable
03	ADV_HDR_TX			Advertise Pdu Header for Tx
		15:8	0	Pdu length
		7:0	0	Pdu type
04	ADV_HDR_RX			Advertise Pdu Header for Rx
		15:8	0	Pdu length
		7:0	0	Pdu type
07	START_TIME			Tx/Rx start time
		23:0	0	Start time
0E	INT_FLAG			Interrupt mask and flag
		15:8	0	Interrupt mask bit
		7	0	Pdu Header OK
		6	0	Pdu OK
		5	0	Pdu Err
		4	0	Tx_Start



		3	0	Mode Err
		2	0	Rx Timeout
		1	0	Enter Sleep
		0	0	Woken up
0F	SLEEP_WAKE			Sleep / wakeup configuration
		31:8	0	Wake up time
		7:2	0	reserved
		1	0	Enable sleep
		0	0	Enable wakeup
10	CLK_CNT			LF clock counter and HF clock counter
		47:24	0	LF clock counter
		23:0	0	HF clock counter
11	TIMEOUT			TX/RX TimeOut (us)
		16	1	Disable Timeout
		15:8	1	Timeout time byte1
		7:0	2c	Timeout time byte0
A0	TX_PLD			TX Data Payload, MaxLen is 31 Bytes

Table 4.1 Register Map

5. 应用电路原理图

下图是 MG127 的典型应用电路原理图。

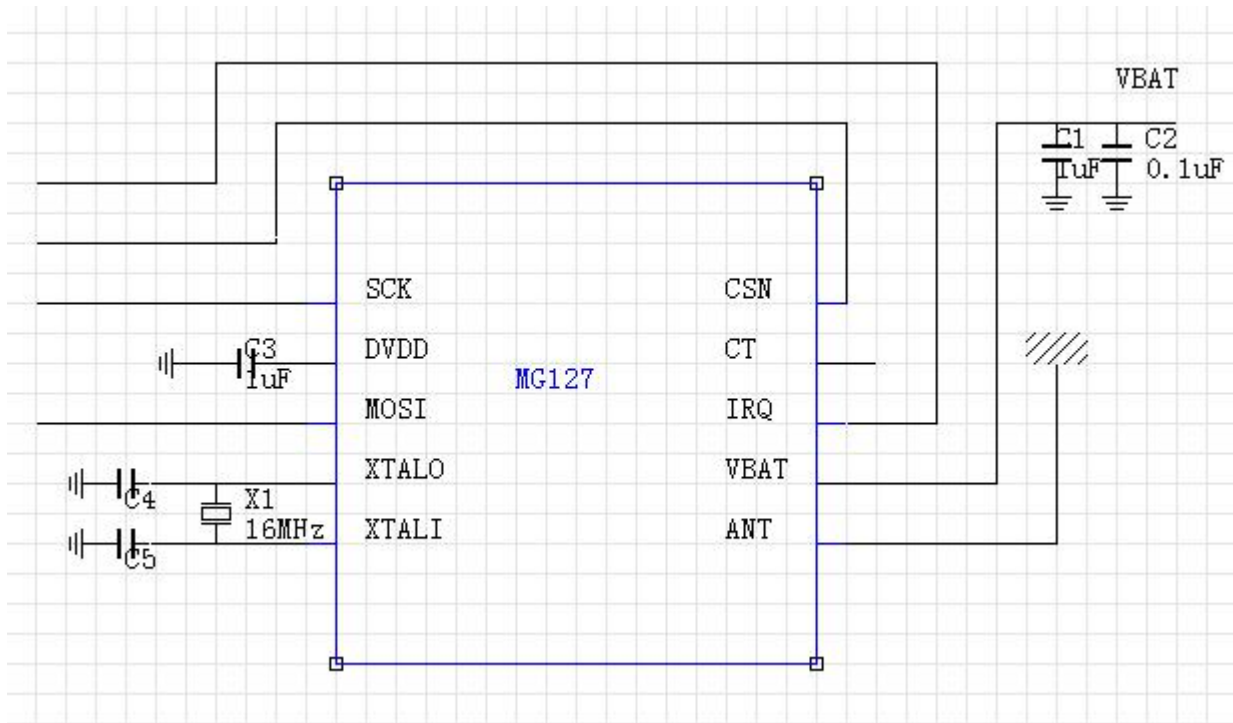

Figure 5.1 example application schematic

6. 电气特性

Conditions: VDD = +3V, VSS = 0V, TA = -40°C to +85°C

Symbol	Parameter	Notes	Min.	Typ.	Max.	Unit
Operating Conditions						
VDD	Supply voltage		1.9	3.0	3.6	V
TEMP	Operating Temperature		-40	+27	+85	°C
Transmitter Operation						
P _{RF}	Maximum output power				+4	dBm
Receiver Operation						
RXSNS	Sensitivity (0.1% BER)			-85		dBm

Table 6.1 Electrical Specification

7. 功耗指标

下表是在 3.0V 供电情况下，MG127 典型的功耗情况。



Mode	Description	Total Typical Current at 3.0v
Standby	待机状态下电流, 通过 spi 唤醒	3 uA
Sleep	待机电流, 不发射不接收	50 uA
TX active	持续发射	20 mA @ 0dBm output power
RX active	持续接收	18 mA

Table 7.1 Current Consumption

8. MG127 封装

DFN10 3mm x 3mm, pitch 0.5mm

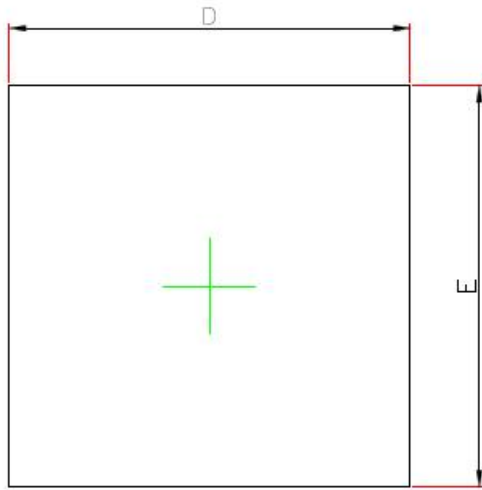

TOP VIEW

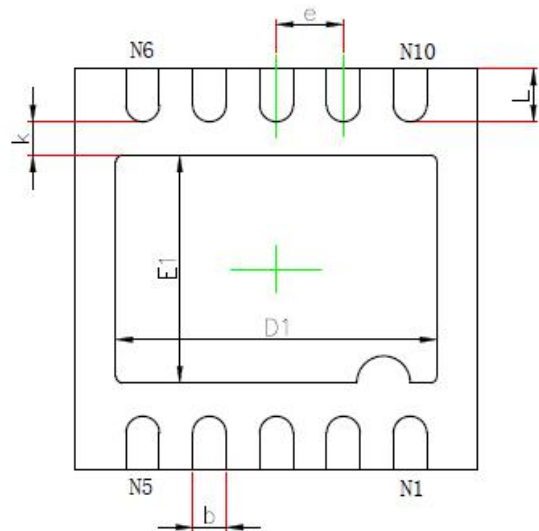

BOTTOM VIEW

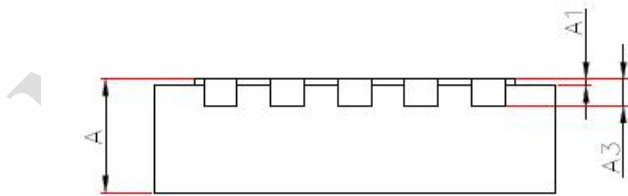

SIDE VIEW

Symbol	Dimensions in Millimeters	Dimensions in Inches
--------	---------------------------	----------------------



	Min.	Max.	Min.	Max.
D/E	2.924	3.076	0.115	0.121
D1	2.300	2.500	0.091	0.098
E1	1.600	1.800	0.063	0.071
k	0.200 MIN.		0.008 MIN.	
b	0.200	0.300	0.008	0.012
e	0.500 TYP.		0.020 TYP.	
L	0.324	0.476	0.013	0.019

Table 8.1 Package outline

9. Reflow Profile

Follow: IPC/JEDEC J-STD-020 C

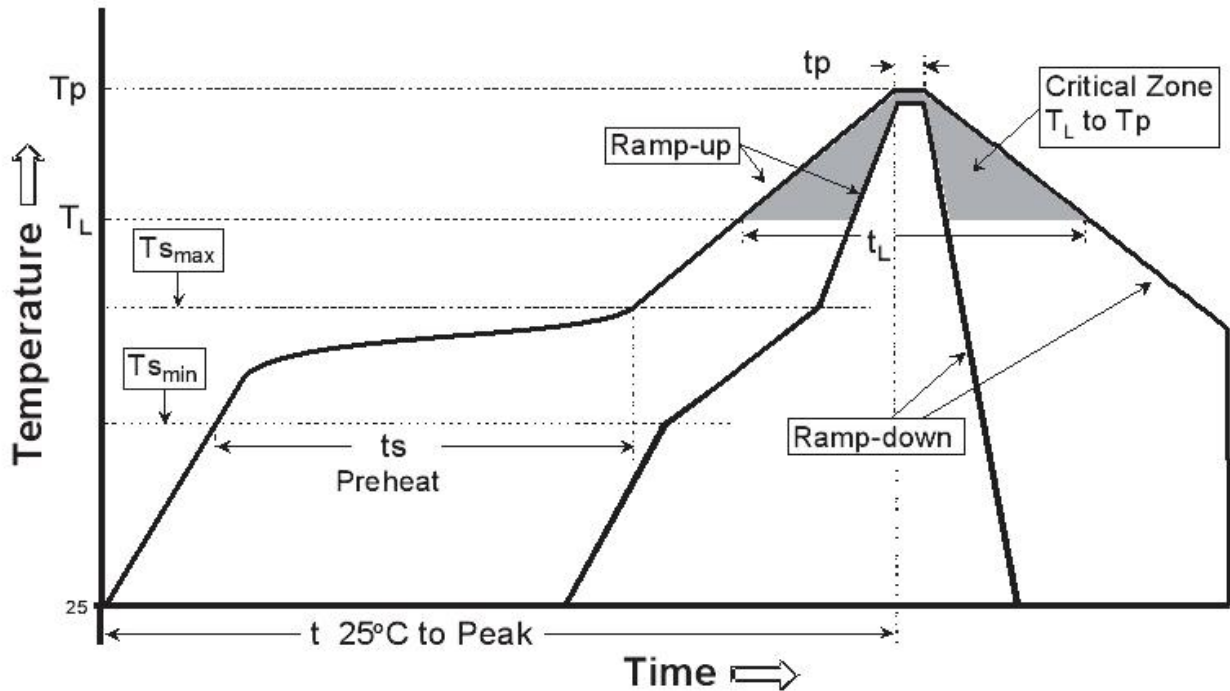

IPC-020c-5-1

Profile Feature	Sn-Pb Eutectic Assembly	Pb-Free Assembly



Average Ramp-Up Rate(TSmax to Tp)	3 °C/second max.	3 °C/second max
Preheat		
-Temperature Min (TSmin)	100 °C	150 °C
-Temperature Max (TSmax)	150 °C	200 °C
-Time (tsmin to tsmax)	60 - 120 seconds	60 - 180 seconds
Time maintained above:		
- Temperature (TL)	183 °C	217 °C
-Time (tL)	60 - 150 seconds	60 - 180 seconds
Peak/Classification Temperature (TP)	225 °C	260 °C
Time within 5 °C of actual Peak Temperature (tp)	10 - 30 seconds	20 - 40 seconds
Ramp-Down Rate	6 °C/second max.	6 °C/second max.
Time 25 °C to Peak Temperature	6 minutes max.	8 minutes max.

10. PCB 布线注意事项

● 电源

电源线、地线的布线直接关系到产品的性能，把噪声干扰降到最低。布线时要尽量加宽地线、电源线宽度，地线>电源线>信号线，通常信号线宽 0.2~0.3mm，电源线宽 1.2~2.5mm，用大面积铜层做地线用，在 PCB 上把没有用的空间都铺成地。

电源加两个电容，如果用 LDO 供电，分别取值 1uF 和 0.1uF 用以滤波；如果用纽扣电池供电，电容分别取值 10uF 和 10uF 用以稳压。

● 晶振

晶振电路要尽量短和对称，靠近芯片，以减少噪声干扰以及分布电容的影响。晶振外壳要良好接地。

● 天线

天线对通信影响很大，请使用成熟的 2.4GHz 天线结构，或者严格按照天线要求制板。一般 PCB 天线需要净空，天线与地（铺铜）之间距离应大于 0.5mm。天线周围不要有元器件或金属结构。

芯片 ANT 到天线之间的走线尽量平滑而且不要太长，线宽要考虑阻抗匹配要求。



11. 载波输出

通过载波输出可以测量 MG127 的射频输出功率，也可以用来调节晶体的负载电容，使晶体工作在正确的频率上。

射频发射信号通过产品的天线耦合到频谱分析仪。测试装置连接如下：

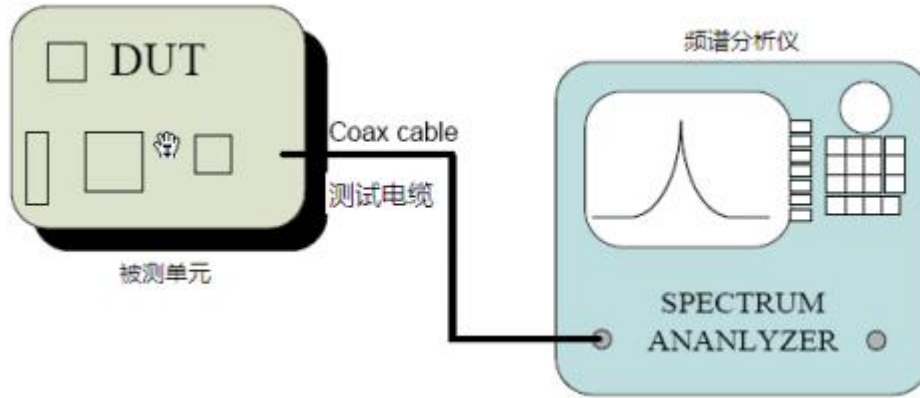

以 2480MHz 载波发射为例，频谱分析仪设置：

- 中心频率设置（Center Frequency）为 2480MHz
- 扫频宽度（Span）为 1~10M
- 最大信号输入幅度（Amplitude）应大于被测产品射频输出功率 3~10 dB
- 分辨率带宽（RBW）为 30K~300KHz（一般自动调整）

在频谱分析仪上可以观察到载波的中心频率和最高幅度。

- 通过调节晶体的负载电容来调节载波中心频率接近 2480MHz（-50KHz，+50KHz）
- 通过调节天线匹配电路使载波幅度在配置范围内

在 16MHz 晶体和 PCB 保持不变的情况下，以上测试只需做一次，确定合适的负载电容值和天线匹配参数。

12. FAQ

1. 问：MG127 典型射频发射功率和功耗？

答：射频发射功率通过参数 BLE_TX_POWER 进行设置。

BLE_TX_POWER(Dec)	BLE_TX_POWER(Hex)	射频发射功率 (dBm)	电流 (mA)
72	48	3	26.9
67	43	0	20.6
64	40	-3	16.7
61	3D	-6	14.8
58	3A	-8	13.5
48	30	-15	10.9
42	2A	-20	10.1



2. 问：MG127 发射数据格式和数据内容？

答：需要符合 BLE PDU 格式。

AdvData 格式 (MG127 数据内容就是 AdvData)

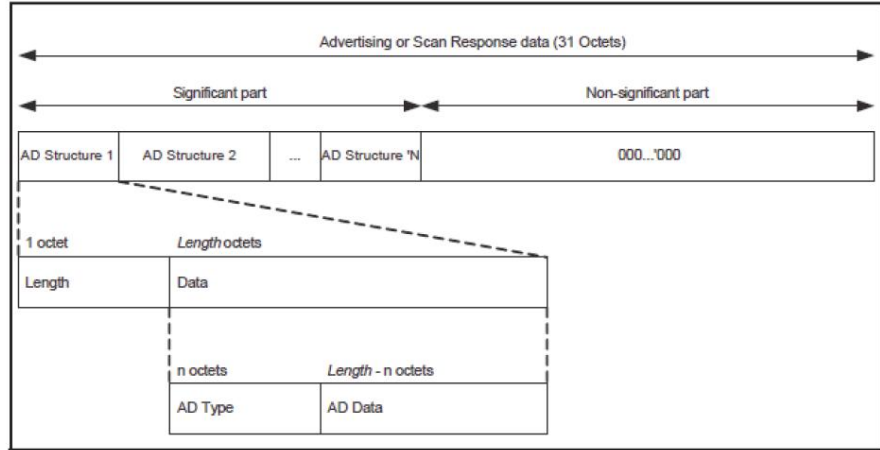

```

Bluetooth Low Energy
Access Address: 0x8e89bed6
Packet Header
  .0.. .... = TX Address: public
  ... 0010 = TYPE: ADV_NONCONN_IND (0x02)
  Length: 36
Advertising Address: 6d:67:17:28:d5:88 (6d:67:17:28:d5:88)
Advertising Data: 0201041aff4c000215fda50693a4e24fb1afcfc6eb076478...
  flags: 0x04
    length: 0x02
    type: Flags (0x01)
    ...0 .... = Simultaneous LE and BR/EDR (Host): False
    ... 0... = Simultaneous LE and BR/EDR (Controller): False
    ... .1.. = BR/EDR not supported: True
    ... ..0. = LE general discoverable: False
    ... ...0 = LE limited discoverable: False
  manufacturer specific data: 4c000215fda50693a4e24fb1afcfc6eb07647825273252a8...
    length: 0x1a
    type: Manufacturer Specific Data (0xff)
    manufacturer specific data: 4c000215fda50693a4e24fb1afcfc6eb07647825273252a8...
CRC: 0x926016

0000 05 06 37 01 a5 01 06 0a 01 27 44 00 00 89 29 00  ..7.... 'D...).
0010 00 d6 be 89 8e 02 24 88 d5 28 17 67 6d 02 01 04  ...$. (.gm...
0020 1a ff 4c 00 02 15 fd a5 06 93 a4 e2 4f b1 af cf  ..L..... 0...
0030 c6 eb 07 64 78 25 27 32 52 a8 ca 92 60 16      ...dx%`2 R...

```

3. 问：MG127 接收数据内容？

答：BLE MAC 地址、BLE Header、BLE ADV data 三部分。

4. 问：如何设置 BLE_START_TIME ？

答：start_time 和 mcu 模拟的 spi 速度有关，如果设置太小会导致接收/发射不成功，如果设置太大会导致不必要的功耗。这个参数需要大于从唤醒中断产生到执行完成 `BLE_Set_StartTime ()` 的时间，如下图所示从标记 T1 到 T2 的时间为 2.46ms，所以 BLE_START_TIME 可以设置为 3ms（留有 0.5ms 左右的裕量）。

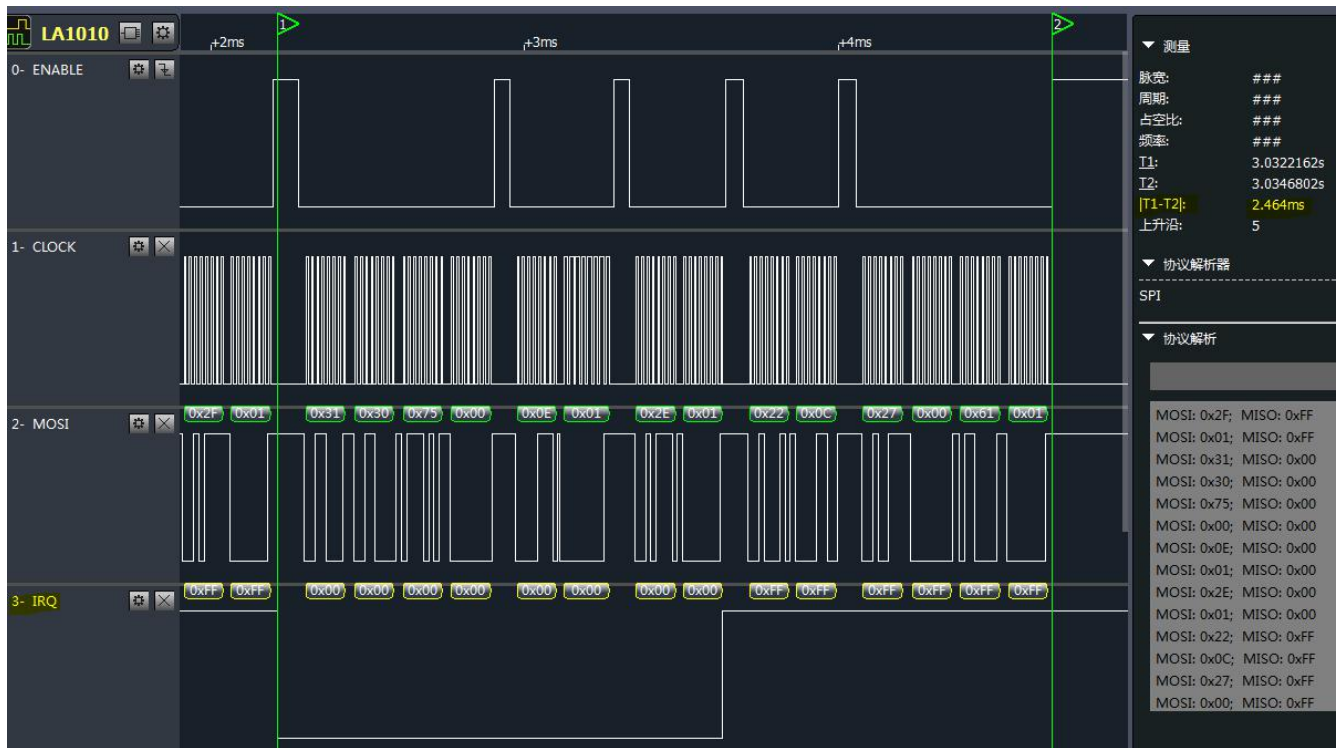

5. TBD