

Practical Considerations for Working With Low-Frequency Oscillators

by: Meera Sridharan, Charles Melear

1 Introduction

Many devices use a 32768 Hz crystal; following are many reasons for choosing this frequency. First of all, it is a power of two, i.e., 32768 is the fifteenth power of two. If an oscillator driven by a 32768 Hz crystal is followed by a divide by 2^{15} circuit, one-second ticks are obtained. Manufacturing techniques have been developed to build these crystals with very high precision. Thus, oscillators can employ these crystals to develop “one-second ticks” with the same percentage accuracy of the crystal frequency. This is why 32768 Hz crystals are so widely used in digital watches and other time-keeping functions.

The 32768 Hz crystals are also used as a clock source for internal PLL/VCO clock circuits on microcontrollers. In addition to the time-keeping functions, another desirable attribute of using a low-speed oscillator in microcontrollers is that they run on batteries. A 32768 Hz CMOS oscillator draws very little power compared to oscillators running at higher frequencies. Power consumption in oscillators is essentially a linear function of frequency. Therefore, using a low-speed oscillator to feed a PLL/VCO clock generation circuit has significant

Table of Contents

1	Introduction	1
2	Selecting External Circuit Components	4
3	Oscillator Start-up Time	5
4	Power Dissipation	6
5	Layout Issues	6
6	Grit and Grime	7
7	Diagnosing Oscillator Problems	8
8	Practical Methods for Evaluating Oscillator Problems	9
8.1	Evaluating Oscillator Start-up Time	9
8.2	Observing Symptoms of Overdriving the Crystal	9
8.3	Choosing the Proper Crystal	10
8.4	Assembly Techniques When Soldering Crystals to Printed Circuit Boards	10
9	Summary	11

implications on power saving in automotive applications, where the microcontroller must run from the power supplied by the car battery, regardless of the time interval during which the car remains parked. When the automobile is not running, the electronic circuit, by using a 32.768 KHz oscillator and driving a PLL/VCO, can turn off the PLL/VCO, so that only the oscillator runs. When the car is started, the PLL/VCO is powered on, and the entire circuit is brought from a low-power state to a fully functional mode.

Using a low-frequency crystal (32768 Hz crystals, generally) presents issues that are not normally major problems with crystals operating in the megahertz range. In general, crystals of this frequency range tend to start much more slowly than high-frequency crystals. Also, 32.768 KHz crystals may attempt to oscillate at overtones or harmonics of the fundamental frequency when they start from a power-on condition. An overtone is a frequency higher than the fundamental frequency but not necessarily a harmonic of the fundamental frequency of the crystal. Physical properties of the crystal determine the frequency of the overtone. A harmonic is an overtone that is a multiple of the fundamental frequency. Hence, the n th harmonic is n times the fundamental. Layout issues, proximity of high-speed conductors near and around the crystal oscillator, and component placement issues also affect the crystal's behavior as the oscillator powers up.

As a practical note, it should be firmly understood that 32768 Hz crystals are neither created equal, nor close. Crystal parameters vary widely between different models produced by the same manufacturer, or between manufacturers and styles of crystals. Designers must be aware that crystal oscillator circuits that require "tweaking" or that must have very high tolerance components to make the oscillator work are going to be marginal, at best. Most oscillators work reliably with components that vary over a reasonable range of values. If a crystal is used that requires high-precision components, the circuit designer should give very special consideration to using a different brand or style of crystal.

Also, as a practical note, when investigating problems with oscillator circuits, great care must be taken with measurement equipment. A typical oscilloscope probe has roughly 10 M ohms of impedance. While this may not sound like very much, it is significant when probing an oscillator circuit. Simply touching the EXTAL (input) pin of an oscillator circuit with a scope probe will significantly alter the characteristics of the circuit and will introduce new problems when trying to analyze existing problems associated with the oscillator circuit.

There are numerous papers written about the mathematical models of oscillators that offer rigorous mathematical treatments. This paper is not intended to duplicate that information. However, it is the business of crystal manufacturers to understand these mathematical models and the physical parameters of their particular crystal, so that they can make recommendations as to what external components should be used with their crystal to build reliable oscillator circuits. The major parameters that crystal manufacturers must know about the microprocessor with regard to specifying external components for the 32768 Hz oscillator circuit are the input and output capacitance of the oscillator pins, EXTAL, and XTAL, respectively, and that the microcontroller has sufficient drive capability for the crystal.

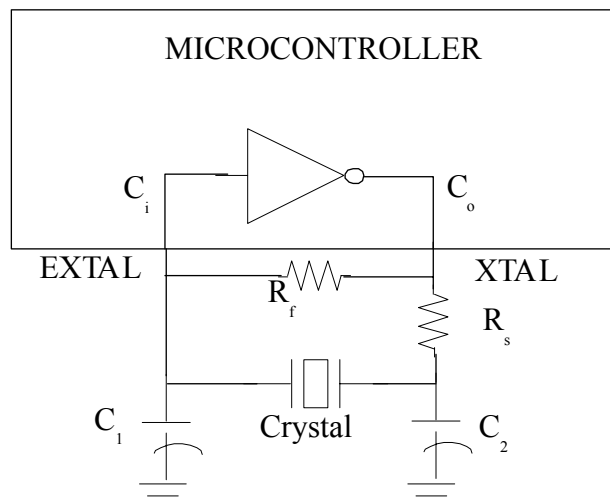

Figure 1. Typical Crystal Oscillator Circuit

The Pierce type oscillator circuit, shown in [Figure 1](#), shows a typical oscillator circuit commonly used in microcontrollers.

This circuit consists of two parts: an inverting amplifier that supplies a voltage gain and a 180 degree phase shift and a frequency selective feedback path. The crystal combined with C_1 and C_2 form a PI network that tends to stabilize the frequency and supply a 180 degree phase-shifted feedback path. In steady state, this circuit has an overall loop gain of one and an overall phase shift that is an integer multiple of 360 degrees.

The inverter for the oscillator is contained within the microcontroller. In actual practice, this is usually a chain of three inverters. However, for the purposes of designing a working oscillator, the inverter can be treated as a single stage. The inverter provides the 180 degrees of phase shift necessary for oscillation.

The crystal is made up of a piezoelectric quartz. A crystal must be chosen that has good self-suppression characteristics for harmonics and overtones. Also, it must lock into the fundamental frequency in an appropriate amount of time. It cannot be emphasized enough that no amount of circuit design can ever compensate for a bad crystal. Crystals are modeled as series R-L-C networks. In the model, R is the equivalent series resistance (ESR). Motional capacitance, C represents the elasticity of the quartz and motional inductance; L represents the vibrating mass of the crystal unit. The C_o , or shunt capacitance, is the capacitance formed by the metal electrodes deposited on each side of the quartz blank, plus the stray capacitance associated with the holder and leads of the component. C_o is generally specified as 7pF maximum. Once again, as a practical matter, the crystal manufacturer should take into consideration these parameters and recommend values for external components.

A property of the inverter is its input capacitance, C_i , and output capacitance, C_o . Sometimes, there will be an internal feedback resistor in the microcontroller. This will definitely affect the external components. If an internal feedback resistor exists, an external feedback resistor, R_f , may not be needed.

The feedback resistor, R_f , is usually 10 - 20 Megohms. This resistor is used to bias the input to the inverter. Because only leakage current flows into the input of the inverter, there should be very little voltage drop across the feedback resistor. This causes the input of the inverter to be pulled toward the voltage on the

output. This, of course, creates an unstable condition, and that is what is needed to form an oscillator. R_f affects the loop gain of the amplifier. Lower values of R_f lower loop gain, while higher values increase loop gain.

The series resistor, R_s , is used to limit the amount of drive current to the crystal supplied from the XTAL pin of the inverter. It is very easy to overdrive the crystal. Therefore, the series resistor must be picked with care. Low-frequency oscillators are very susceptible to problems caused by being overdriven. The manufacturer of the crystal is probably the best source of information for picking a value for R_s . R_s must be large enough to limit the current to the crystal but, at the same time, be small enough to provide enough current to start oscillation quickly. If R_s is too small, the crystal will start up in unpredictable modes or dissipate too much power. This can cause heating problems and, in extreme cases, even damage the crystal. On the other hand, if R_s is too large, the oscillator will start slowly or not start at all.

The bypass capacitors, C1 and C2, are used, in part, to create a low-pass filter. The capacitive load on one side of the crystal should be roughly equal to the capacitive load on the other side of the crystal. In many circuits, designers make C1 equal to C2. Because the output capacitance of the inverter is usually a few picofarads greater than the input capacitance, the bypass capacitor on the EXTAL pin can be a little larger than the bypass capacitor on the XTAL pin.

The circuit and layout capacitances also add to the values of C1 and C2. The correct choices of C1 and C2 are very important to oscillator start-up and steady-state conditions. Imbalances in capacitive and inductive impedance can cause phase and amplitude problems in the feedback loop.

As a practical matter, if a few picofarads of capacitance make a difference between whether or not the oscillator works, the oscillator circuit definitely has significant design problems that should be investigated.

2 Selecting External Circuit Components

The external oscillator circuit components are chosen with respect to two major goals. First, the power supplied to the crystal must be limited to prevent overdriving the crystal, as well as limited to the extent that the crystal will not start, and, second, to form a low-pass filter that suppresses frequencies above the crystal's fundamental frequency.

The frequency vs. amplitude characteristics of a typical low-pass filter are presented in [Figure 2](#).

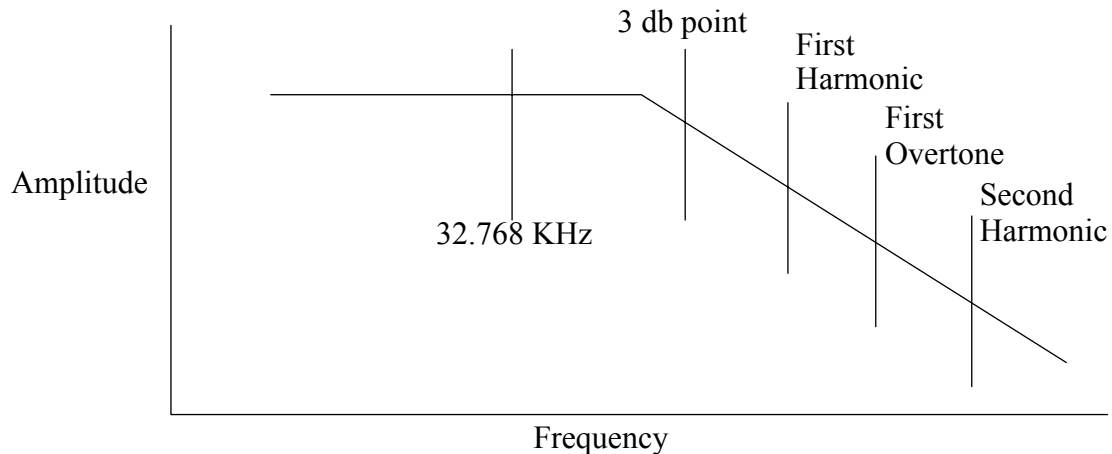

Figure 2. Frequency vs. Amplitude Characteristics of a Typical Low-pass Filter

The goal is to set the three db point of the filter roughly halfway between the fundamental crystal frequency and the crystal's first harmonic. In the present case, the three db point should be approximately 50 KHz. C_i , C_o , C_1 , C_2 , R_f , R_s , and the impedance of the crystal all figure into the calculation of the low-pass filter characteristics. Because of the difficulty in determining the characteristics of the crystal, it is always a wise practice to obtain recommendations from the crystal's manufacturer in selecting the external oscillator-circuit components. Recall that crystal parameters vary over a wide range between manufacturer and styles of crystals. Design engineers must realize that the external component values for one type/brand of crystal may be totally different for another type/brand of crystal.

3 Oscillator Start-up Time

As previously stated, the start-up time for low-speed oscillators (under 100 KHz) is relatively slow when compared to high-speed oscillators (several megahertz and greater). While high-speed oscillators may reliably start in a few hundred microseconds, low-speed oscillators typically start in a few milliseconds. Start-up times for 32.768 KHz crystals of 200 - 400 milliseconds are very common. When measuring start-up time, it is important not to disturb the oscillator circuit. Putting a typical scope probe on the EXTAL or XTAL pin usually constitutes a significant loading factor on the oscillator circuit and will affect observed values. A reasonably accurate start-up time can be obtained by measuring the time difference between the application of power and observing some type of buffered form of the oscillator output. Often, there will be an "oscillator out" signal from the microcontroller. In other cases, the 32.768 KHz oscillator may be driving a VCO, which is internal to the microcontroller, and the output of the VCO will appear on a package pin. Another way to indirectly measure the output of the oscillator is to apply the XTAL output pin to a logic gate or buffer and then measure the output of the buffer with an oscilloscope. The value of the bypass capacitor in the oscillator circuit will need to be decreased by the value of the input capacitance of the buffer, so that it does not change the oscillator circuit loading parameters. By observing the output of the buffer with an oscilloscope instead of the XTAL pin, a reliable measurement can be obtained to determine when the oscillator has started with respect to the application of power.

The time between the application of power to the oscillator circuit and observing a stable, buffered form of the 32.768 KHz signal should be in the range of 200 - 400 milliseconds. If the start-up time for the crystal is less than 200 milliseconds, the circuit should be carefully evaluated for the presence of unusual oscillator modes, overtone frequencies, and various harmonics. Recall that crystals may attempt to start at the first overtone and that overdriving the crystal will aggravate this condition. Also, crystals can start at the first overtone and then quickly switch to the fundamental crystal frequency. This can be particularly troublesome if the output of the 32.768 KHz oscillator is driving a VCO with a relatively high multiplication factor.

Another problem that can result in extreme cases of being overdriven is unpredictable oscillation modes. When using low-frequency “tuning fork” elements, the frequency of oscillation is determined by the length of the “fork.” However, if the element is grossly overdriven, just the very tips of the “fork” may oscillate. This is usually at a frequency greater than ten times the fundamental. When this happens, the “tuning fork” probably will not be able to recover until power is removed from the circuit.

Although the case just described is extreme, one must recall the wide range of parameters found in crystals. A series resistor of 50 K ohms may be optimal for one type or brand of crystal but result in a case of extreme overdriving for another type or brand of crystal. Once again, it is very important to consult the applications information supplied by the crystal manufacturer rather than the integrated circuit manufacturer for proper applications information.

At the other end of the spectrum is under-driving the crystal. These problems are much easier to diagnose because the symptoms are that the crystal will not start at all or it takes a very long time (greater than one second) to start. In this case, a designer can use successively lower (fewer ohms) series resistor values until reliable starting times of approximately 200 to 400 milliseconds are observed.

Because of the transient nature of oscillator start-up phenomena, i.e., temporary oscillation modes, it is sometimes difficult to determine that this is the root cause of system failures. Therefore, it is important to fully evaluate the start-up characteristics of crystal oscillators before committing to production.

4 Power Dissipation

This topic is related to the reliability of operation over time than with getting the crystal to oscillate. While a crystal is an “open circuit” to a DC voltage, it definitely presents an impedance to an AC voltage. In other words, the crystal will dissipate energy, just like a resistor, inductor, or capacitor, when stimulated by an alternating pattern. Crystal manufacturers generally evaluate the permissible levels of power needed to insure proper crystal operation. Exceeding those levels will certainly reduce crystal life expectancy and, in some cases, will actually damage the crystal.

Some designers overdrive the crystal to get shorter oscillator start-up times. It is imperative that crystal parameters with respect to power dissipation be strictly observed since overdriving the crystal creates many more problems than it solves.

5 Layout Issues

In general, low-frequency oscillator components, i.e., the crystal, bypass capacitors, series resistor, and feedback resistor should be as physically close to the microcontroller’s oscillator pins as possible. It has

been previously stated in this paper that properly designed oscillator circuits employed with a high quality crystal can tolerate a reasonably wide range of component values and still yield acceptable operation. However, there are definitely limits to the range of component values. For instance, 20 pf bypass capacitors may be optimal while 50 pf bypass capacitors may be so large that they will not allow the circuit to oscillate.

Improper component layout techniques can result in unintended consequences, which add to capacitance values. For instance, if the bypass capacitors are placed several inches away from the microcontroller, lead capacitance can easily add 10 to 30 pf to the value of the bypass capacitors. Causing a differential of 30 pf between the bypass capacitors has a significant potential for causing start-up problems with the oscillator.

A second layout issue concerns conductors carrying high-frequency signals being routed near any of the external oscillator components. Because of the high impedance of many of the circuit components, capacitive coupling can become quite problematic. If a noise spike is coupled into the input of the microcontroller's internal inverter, the spike will be reflected in the inverter's output which in turn, will cause a significant perturbation in the amplifier. That is, the noise spike may induce the crystal to oscillate in an unpredictable mode. Since low-frequency crystals are often used with VCOs that have large multiplication factors, any noise introduced into the oscillator circuit will be multiplied by the VCO.

It cannot be stated with enough emphasis that all the external oscillator components must be located very close to the EXTAL and XTAL pins of the microcontroller. Also conductors carrying high-frequency signals or any signals with very sharp edges must be kept away from the oscillator components. If the 32.768 KHz signal is being used to drive a Real Time Clock and noise spikes get coupled into the oscillator output, the Real Time Clock will "gain" time. Since these spikes will probably occur at a relatively low rate compared to 32.768 KHz, the "creep" in the actual time will not show up very fast. What is often observed with noise coupling is that the real time clock will gain a few seconds per hour or per day. Even a few seconds per day is a very significant error for a real time clock.

If the 32.768 KHz oscillator is driving the input of a PLL/VCO, a noise spike in the oscillator output will look like an instantaneous doubling of the input frequency to the PLL/VCO. This, in turn, can cause the VCO to take a very large frequency swing. If the output of the PLL/VCO is supplying the system clock for a microcontroller, the output of the PLL/VCO can easily swing well outside the operating frequency of the microcontroller and cause the entire system to become inoperative.

6 Grit and Grime

Oscillators are quite sensitive to dirt, solder flux, grease, condensation due to high humidity, and other conducting materials on the circuit board. These materials can allow a high-resistance leakage path from one of the amplifier pins to either the ground or positive terminal of the power supply. When the oscillator has power applied but has not started to oscillate, the crystal and the bypass capacitors appear as DC open circuits. An oscillator in a DC condition would appear as shown in [Figure 3](#).

The resistor, R_d , represents a high-resistance leakage path, within the range of five to 20 megohms. The feedback resistor, R_f , is also in this range. Assuming that R_d and R_f are both ten megohms, the voltage at point A is one-half the voltage difference between points B and C. Thus, if the XTAL pin is at a logic one (4.5 volts), and point C is at ground, the voltage at point A (EXTAL pin) will be 2.25 volts. If point B is at a logic zero (0.5 volts), and point C is at ground, the voltage at point A is 0.25 volts. Thus, the voltage

at point A may be interpreted as a logic zero regardless of whether the XTAL pin is a logic one or a logic zero. This depends on the threshold of the inverter whose input is connected to point A. Likewise, if point C is connected to 5 volts, point A may be interpreted as a logic one regardless of the state of the XTAL pin. A circuit with this problem will not oscillate.

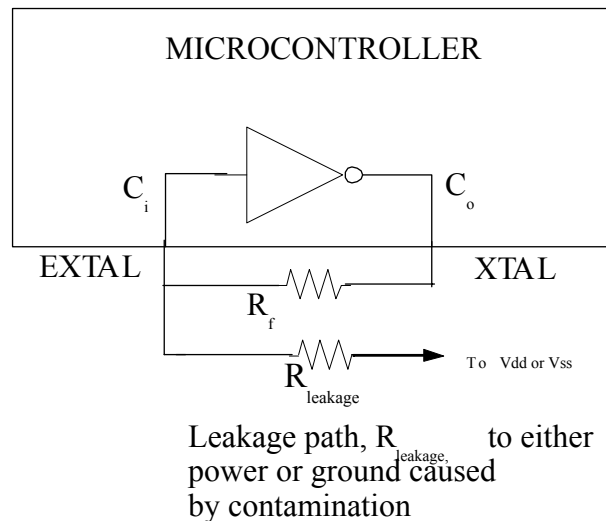

Figure 3. Oscillator Configuration In a DC Condition

The only way to diagnose this problem is to remove the external circuit components, as well as the MCU from the board, and use an ohm meter to check the resistance from points A and B to ground and five volts. Anything other than a completely open circuit is a sign of trouble. Leakage paths of several megohms will definitely cause trouble. The obvious solution is to clean the printed circuit board. If the dirt, grime, or other conducting material that forms the high-resistance path is on an inner layer of the printed circuit board, the board will most likely be unusable. If the leakage is due to condensation on the board, spray the oscillator circuit with a protective coating.

7 Diagnosing Oscillator Problems

Oscillator problems present a particular challenge in finding errant conditions. One reason that oscillator problems are hard to diagnose is that the problems are often transient in nature. The second challenge is that almost all measurement equipment will perturbate the system to a sufficient degree that problems caused by the test equipment cannot be separated from errant component or layout issues. Looking at the diagram shown in [Figure 3](#), it was shown that a leakage path caused by some type of conductive film could form a high resistance “sneak” path to either Vdd or Vss. A typical oscilloscope probe will often have a 10 Megohm input resistance. There is no practical difference between a leakage path created by “grit and grime” and that caused by an oscilloscope probe. If at all possible, look at a buffered form of the oscillator output, so that perturbations are not created by the test equipment.

8 Practical Methods for Evaluating Oscillator Problems

8.1 Evaluating Oscillator Start-up Time

One method for evaluating oscillator start-up time is to observe a buffered form of the oscillator with respect to the application of power to the circuit. A dual trace scope can be employed for this purpose. One probe is placed on the Vdd pin of the oscillator circuit, and the other scope probe is placed on the “clock output” pin of the microcontroller. Most microcontrollers have some form of clock output pin. The oscilloscope is set to trigger on the rising edge of Vdd, i.e., trigger upon the application of power. Two characteristics of the system can be observed. One is the rise time of the power supply, and the other is the delay between the time that Vdd reaches its proper operating range and the appearance of a clock signal at the proper frequency on the “clock out” pin of the microcontroller. Crystals require a certain amount of power to start into a stable oscillation pattern. Since the power supplied to the crystal is going to be a function of the power supply, oscillator start-up times are going to be strongly affected by the rise time of the power supply. Another factor is that a power supply with very sharp rise times will act like an impulse to the crystal, causing it to start faster when compared to using a power supply with a very slow rise time. By picking a specific voltage, i.e., the minimum operating voltage for the microcontroller, a standard measuring point can be used for timing measurements.

In general, an oscillator start-up time for a 32.768 KHz crystal should be within the range of 200 - 400 milliseconds. (Note: Start-up times exceeding 700 milliseconds are probably so long that they indicate the crystal is having trouble starting at all, and the value of the series resistor should be reduced.) If the microcontroller does not have a buffered form of the oscillator, another method can be employed to evaluate start-up time. A buffer can be connected to the XTAL pin of the microcontroller circuit, shown in [Figure 1](#). The load capacitor on the XTAL pin should be reduced by the amount of the input capacitance of the buffer. This keeps the capacitive load on the XTAL pin the same as before the buffer was added. The measurement point for the oscillator start up is now the output of the buffer connected to XTAL. This method is used, of course, to keep the measurement equipment from perturbing the system being evaluated.

8.2 Observing Symptoms of Overdriving the Crystal

Once again, it is important that the measuring equipment does not perturbate the system. Therefore, a buffered form of the oscillator signal should be observed, or measuring equipment with extremely high impedance should be used. This means that scope probes should have an input impedance which is much greater than the feedback resistor shown in [Figure 3](#).

When a crystal is overdriven, the crystal will often attempt to start at an overtone or the first harmonic. In extreme cases, the crystal will enter some undefined oscillation mechanism that may not be a harmonic or overtone frequency at all. Observing this behavior is particularly difficult because it can be transient in nature and the duration of the transient phenomena can be less than a few milliseconds. However, these transient perturbations of the crystal can result in high-frequency signals that can cause the microcontroller to enter an unrecoverable state.

One method to observe these transient states is to take an oscilloscope with a high repetition rate (as opposed to sampling rate). Analog oscilloscopes and digital scopes, when used with low sampling rates, generally have fairly high repetition rates. By carefully observing the scope as power is applied to the circuit, transient phenomena can often be seen visually when they are present. This method of observation is somewhat coarse in nature and will not yield accurate results in determining the exact nature of the transient phenomena. However, it can provide an indication that the oscillator is starting in an abnormal manner. If an abnormal pattern is observed, a memory scope can be employed for further evaluation. Recall that crystals can start at the correct frequency, jump to some type of abnormal mode, and then return to a normal pattern.

If any type of abnormal, transient phenomena are observed, two basic solutions can be employed. The first solution is to increase (a greater number of ohms) the size of the series resistor of the oscillator circuit. If this does not solve the problem, use a different brand or style of crystal. Different styles of crystals, even those produced by the same manufacturer, can have significantly different characteristics. The same is true for different manufacturers of the same type of crystal. As a practical consideration, when circuit-board layout issues are not causing problems, and the series and feedback resistors and bypass capacitors of the crystal oscillator circuit are required to be within extremely tight limits to insure proper crystal operation, the crystal itself is probably marginal, and consideration should be given to selecting a different brand / type of crystal. If a crystal has poor overtone or first harmonic suppression, no amount of external circuit design will compensate for this. The same is true for drive currents. If the crystal requires a very narrow range of series resistor values for proper start-up characteristics, it is a wise idea to consider a different brand / style of crystal.

8.3 Choosing the Proper Crystal

Low-frequency tuning elements tend to be much larger than their high-frequency counterparts. In general, low-frequency tuning elements are more susceptible to physical damage due to stressful operating environments. Automotive operating environments are among the most challenging because of their high vibration and temperature extremes. When picking a 32.768 KHz crystal, it is important to obtain qualification data from the manufacturer regarding the type of environment the particular crystal is qualified to operate.

8.4 Assembly Techniques When Soldering Crystals to Printed Circuit Boards

Low-frequency tuning elements are more sensitive to temperature than their high-frequency counterparts. In general, low-frequency crystals can be damaged more easily than high-frequency elements in soldering processes. Particular attention must be paid to keeping soldering operations within temperature ranges that will not damage the crystal. While high-temperature damage can manifest itself in many ways, the most common symptom is the failure of the crystal to operate. Another way for temperature damage to express itself is for the crystal to display bizarre or unexplainable start-up characteristics. If problems with a crystal suddenly appear in a product line that previously had no problems, assembly soldering temperatures are a good place to investigate.

9 Summary

Low-frequency oscillator circuits can be reliably produced and made to perform with accuracy and stability. It has been stated several times in this paper that crystals, themselves, vary widely in many characteristics, including power dissipation, harmonic and overtone suppression, temperature drift, and accuracy. It is difficult, and of questionable design practice, to attempt circuit designs that must compensate for a crystal with poor operating characteristics. Careful attention must be given to selecting external circuit components that allow the crystal to operate within its proper range of power dissipation, temperature, and voltage requirements. Good quality, low-frequency crystals generally do not require high-tolerance components. Having to use high precision capacitors and resistors in the oscillator circuit are often a very clear indication that the crystal being used does not have good internal characteristics.

While this paper has dealt with problems associated with low-frequency oscillators, it must be stated that many brands and styles of 32.768 KHz crystals have been used for many years. They have served reliably in their intended applications. By observing a few basic precautions and being aware of simple measurement techniques, reliable low-frequency oscillators can be properly designed and used for microcontroller applications.

How to Reach Us:

Home Page:

www.freescale.com

E-mail:

support@freescale.com

USA/Europe or Locations Not Listed:

Freescale Semiconductor
Technical Information Center, CH370
1300 N. Alma School Road
Chandler, Arizona 85224
+1-800-521-6274 or +1-480-768-2130
support@freescale.com

Europe, Middle East, and Africa:

Freescale Halbleiter Deutschland GmbH
Technical Information Center
Schatzbogen 7
81829 Muenchen, Germany
+44 1296 380 456 (English)
+46 8 52200080 (English)
+49 89 92103 559 (German)
+33 1 69 35 48 48 (French)
support@freescale.com

Japan:

Freescale Semiconductor Japan Ltd.
Headquarters
ARCO Tower 15F
1-8-1, Shimo-Meguro, Meguro-ku,
Tokyo 153-0064
Japan
0120 191014 or +81 3 5437 9125
support.japan@freescale.com

Asia/Pacific:

Freescale Semiconductor Hong Kong Ltd.
Technical Information Center
2 Dai King Street
Tai Po Industrial Estate
Tai Po, N.T., Hong Kong
+800 2666 8080
support.asia@freescale.com

For Literature Requests Only:

Freescale Semiconductor Literature Distribution Center
P.O. Box 5405
Denver, Colorado 80217
1-800-441-2447 or 303-675-2140
Fax: 303-675-2150
LDCForFreescaleSemiconductor@hibbertgroup.com

Information in this document is provided solely to enable system and software implementers to use Freescale Semiconductor products. There are no express or implied copyright licenses granted hereunder to design or fabricate any integrated circuits or integrated circuits based on the information in this document.

Freescale Semiconductor reserves the right to make changes without further notice to any products herein. Freescale Semiconductor makes no warranty, representation or guarantee regarding the suitability of its products for any particular purpose, nor does Freescale Semiconductor assume any liability arising out of the application or use of any product or circuit, and specifically disclaims any and all liability, including without limitation consequential or incidental damages. "Typical" parameters that may be provided in Freescale Semiconductor data sheets and/or specifications can and do vary in different applications and actual performance may vary over time. All operating parameters, including "Typicals", must be validated for each customer application by customer's technical experts. Freescale Semiconductor does not convey any license under its patent rights nor the rights of others. Freescale Semiconductor products are not designed, intended, or authorized for use as components in systems intended for surgical implant into the body, or other applications intended to support or sustain life, or for any other application in which the failure of the Freescale Semiconductor product could create a situation where personal injury or death may occur. Should Buyer purchase or use Freescale Semiconductor products for any such unintended or unauthorized application, Buyer shall indemnify and hold Freescale Semiconductor and its officers, employees, subsidiaries, affiliates, and distributors harmless against all claims, costs, damages, and expenses, and reasonable attorney fees arising out of, directly or indirectly, any claim of personal injury or death associated with such unintended or unauthorized use, even if such claim alleges that Freescale Semiconductor was negligent regarding the design or manufacture of the part.

Freescale™ and the Freescale logo are trademarks of Freescale Semiconductor, Inc. All other product or service names are the property of their respective owners.

© Freescale Semiconductor, Inc. 2004, 2005. All rights reserved.